

# **Midterm Exam**

**ECE 448  
Spring 2008**

**Wednesday Section**

**(15 points)**

## **Instructions**

Zip all your deliverables into an archive <last\_name>.zip and submit it through WebCT no later than Wednesday, March 5, 10:00 PM EST.

## Introduction

Design a circuit that accepts samples from two A/D converters, provided at the inputs A and B, respectively, as 8-bit unsigned numbers. The samples are generated by each A/D converter in groups of four, with each member of a group being separated by 20 ns. A period of 200 ns separates each group of samples. The circuit should compute an average value of the four samples within each group, and then compare the average value of input A with that of input B. Upon computing the average values of A and B, the circuit then determines which of the two is greater. If A is greater than B, the value of COUNT is increased by one; if B is greater than A, the value of COUNT is decreased by one; and if the two values are equal, the value of COUNT does not change. When COUNT reaches a threshold of +5, it should not be able to increment to +6. Instead of incrementing, the OVERFLOW output should be set high. Similarly, when COUNT reaches -5, it should no longer decrement; instead UNDERFLOW will be set high. COUNT, OVERFLOW, and UNDERFLOW should remain unchanged in the period between two consecutive comparisons. When one iteration of the comparison algorithm has been completed, NEW\_COUNT should be set high for one clock cycle.

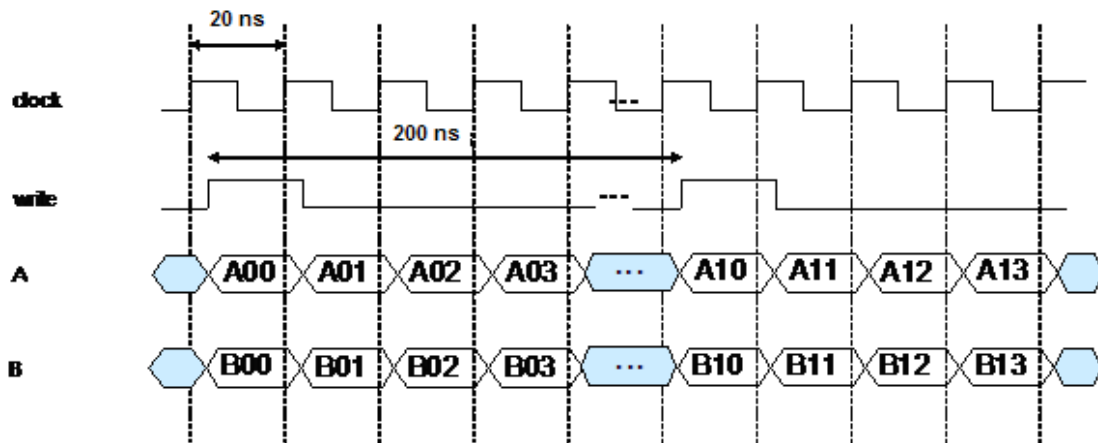

The pseudocode for calculation is shown below:

```

COUNT = 0
While (TRUE)
    Wait until RECORD_DATA = '1'
    A_Reg = 0
    B_Reg = 0
    For i in 0 to 3 loop
        A_Reg = A_IN + A_Reg
        B_Reg = B_IN + B_Reg
    End loop

    A_Average = A_Reg / 4
    B_Average = B_Reg / 4

    If A_Average > B_Average
        If COUNT == 5
            UNDERFLOW = '0'
            OVERFLOW = '1'
            COUNT = COUNT
        Else
            COUNT = COUNT + 1
        End If
    Else If B_Average > A_Average
        If COUNT == -5
            UNDERFLOW = '1'
            OVERFLOW = '0'
            COUNT = COUNT
        Else
            COUNT = COUNT - 1
        End If
    End If

    NEW_COUNT = 1
End While

```

```
                UNDERFLOW = '0'  
                OVERFLOW = '0'  
                COUNT++  
            End if  
Else if B_Average > A_Average  
    If COUNT == -5  
        UNDERFLOW = '1'  
        COUNT = COUNT  
        OVERFLOW = '0'  
    Else  
        OVERFLOW = '1'  
        UNDERFLOW = '1'  
        COUNT--  
    End if  
Else  
    COUNT = COUNT  
    UNDERFLOW = '0'  
    OVERFLOW = '0'  
    NEW_COUNT = '1'  
End While
```

Assume the following interface to your circuit:

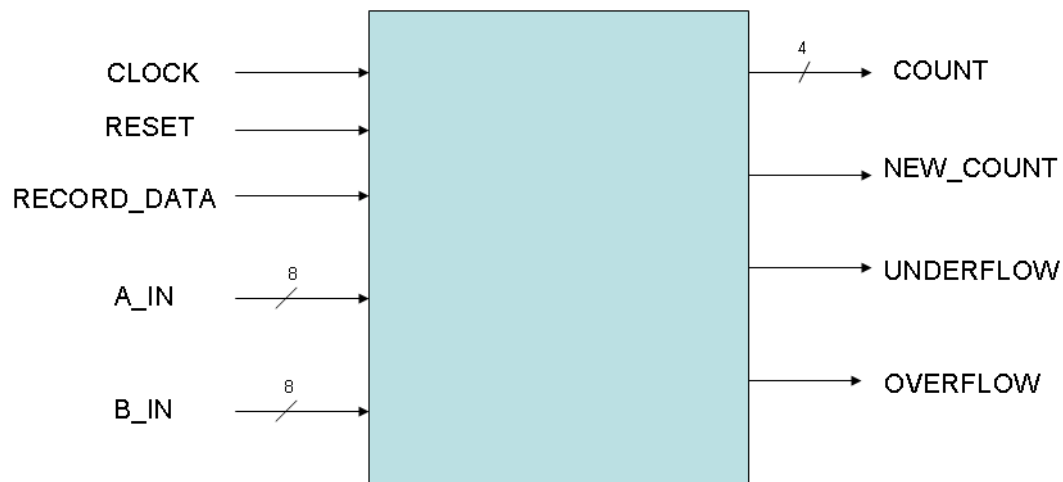

Port	Mode	Width	Function
CLOCK	Input	1	System clock
RESET	Input	1	System reset
A_IN	Input	8	Input A for samples produced by the first A/D converter
B_IN	Input	8	Input B for samples produced by the second A/D converter
RECORD_DATA	Input	1	Signal set to high when the first sample of each group of four is present at the inputs A and B
COUNT	Output	4	Value of the special Counter
OVERFLOW	Output	1	Indication of an OVERFLOW
UNDERFLOW	Output	1	Indication of an UNDERFLOW
NEW_COUNT	Output	1	Set to HIGH for one clock cycle when a new value of COUNT is computed

The execution unit for the circuit is shown below. Note that all inputs that are in capital letters are external inputs. Inputs that are written with lowercase letters are inputs from a control unit.

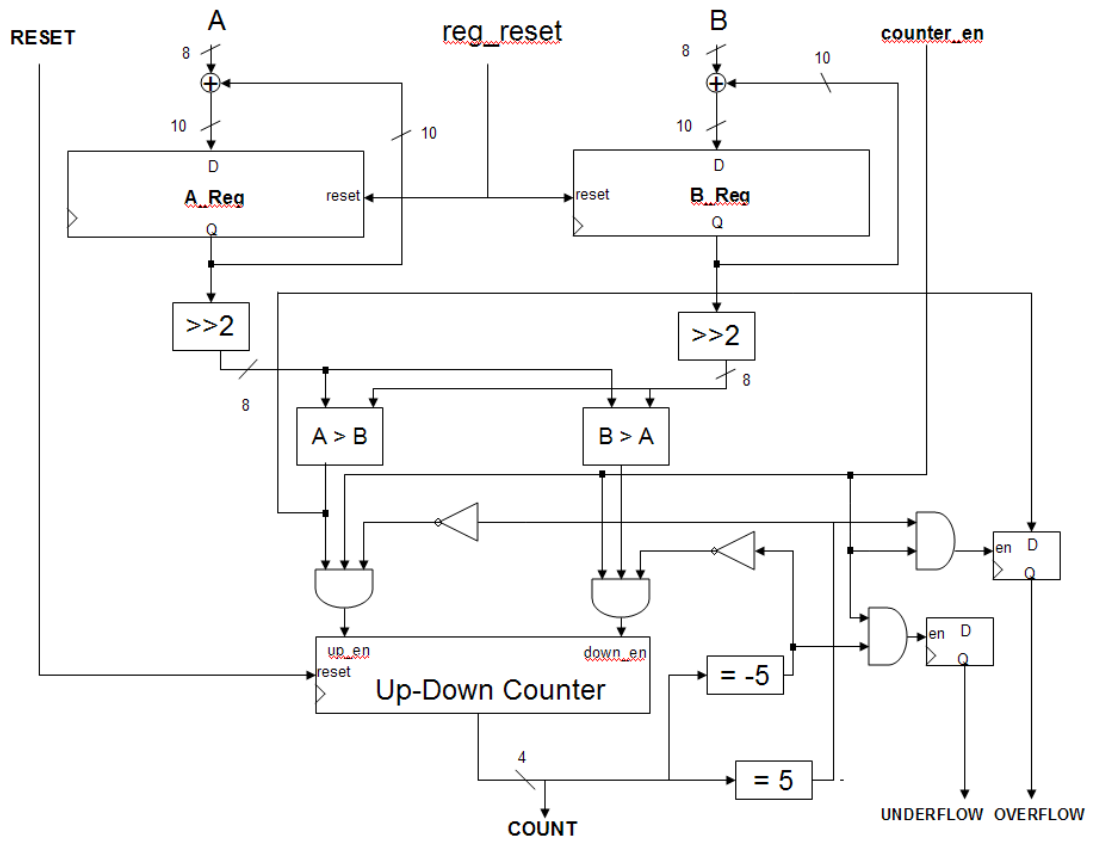

The timing waveforms for a series of computations are shown below:

