

Lecture 26 RAT: Sections 9.0-9.2 of O/S/B draft chapter 9

1. Name _____
2. T/F The decimation-in-frequency algorithm is derived by taking the log of the input sequence and decimating it.
3. T/F The FFT is a new type of transform that is completely unrelated to the DFT.
4. T/F FFT stands for *Frequency Fitting Transform*.
5. T/F Oppenheim, Schafer, and Buck use the complex phase angles as a measure of an algorithm's computational complexity.

In-class #1: warmup

Sketch the signal $x[n]$ and compute its 4-point DFT:

$$x[n] = 4\delta[n] + 3\delta[n - 1] + 2\delta[n - 2] + \delta[n - 3].$$

In-class #2

Compute the 2-point DFT of the following signal:

$$x[n] = 6\delta[n] + 4\delta[n - 1].$$

Write formulas for the 2-point DFT of any signal $x[n]$, *i.e.*, write equations for $X[0]$ and $X[1]$ in terms of $x[0]$ and $x[1]$.

In-class #3

Determine the values for the missing coefficients (A , B , C , and D) in the following decimation-in-frequency flowgraph for a 4-point transform.

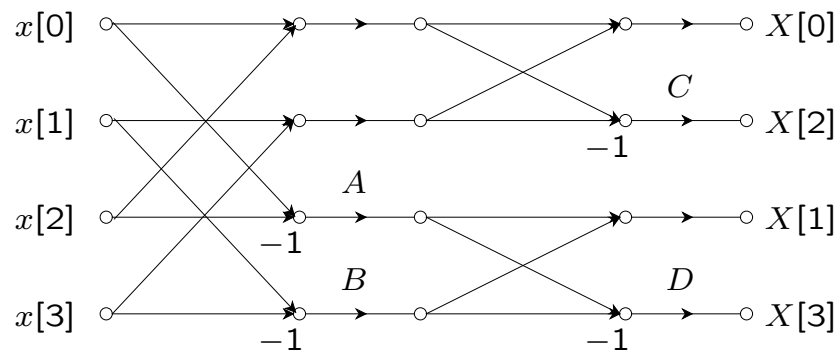

Verify that the flowgraph produces the correct DFT result for the signal $x[n]$ from In-class #1.